

Operation Manual

Let me personally thank you for purchasing the Behmor 1600. I'm 100% positive the coffees roasted will be the freshest you've ever enjoyed. Until recently, only those in the coffee business almost exclusively enjoyed this coffee experience. The Behmor 1600 changes that. You'll quickly come to find, as I did, that roasting coffee is easy to do, will provide you immeasurable pleasure along with unparalleled coffee.

I'd also like to take a moment to tell you the Behmor 1600 has been designed and manufactured to meet the low pollution standards known as RoHS aka reduced hazardous substances. No agency has required I do this. It is my personal belief we as individuals and companies make the difference. I've also requested, that where possible, all packing material is recyclable and I urge you to recycle this material.

Thank you again and may the Behmor 1600 enable you to enjoy the coffee experience at a higher level than what you are used to.

Joseph Behm
Inventor and designer

Part 1: Introduction to the Behmor 1600

The Behmor 1600:

The Behmor 1600 is the world's first and only one-pound capacity home coffee roaster. When used with high quality beans, the Behmor 1600 utilizing patent pending smoke suppression technology roasts in virtually every application with no visible smoke up to second crack (term explained later). It is also the only home roaster in the world manufactured with a variable speed motor to facilitate proper bean rotation, plus allow for higher, more efficient cooling and chaff removal. In addition, the Behmor 1600's variable-speed fan controls allow for optimum functionality.

The Behmor 1600 will, in the overwhelming majority of cases, take up to a single pound of green coffee into second crack without emitting visible smoke. For Full City+ roasts, we recommend you reduce the quantity of the roast to ½ pound. The Behmor 1600 is not intended nor meant to roast coffee to levels known as Vienna, French, and Italian or darker.

In all cases follow the safety guidelines of roasting in a well-ventilated environment and other points mentioned in the Safe Guards area.

The Behmor 1600 has been designed to allow the user the option of a quick start method or other easy-to-use programmable options to adjust roast times, roast profiles, and cooling times. Like other aspects of the roaster, the control panel is designed for ease of use. The system has designated weight allowances that coordinate and adjust to various times according to the weight entered. These times create a starting point that can be adjusted to a more precise setting by using the + / - buttons. To add even greater value and provide further options the system has been designed to afford the user the option to choose various roast profiles that can slightly alter the nuances of each coffee to better suit each individual's varying tastes or better suited for a particular bean.

Cooling is an equally important aspect of insuring the finest of end results when roasting. The Behmor 1600 is pre-programmed to immediately go into a cooling cycle once the roast cycle has been completed. It can also be controlled manually. Both cooling features utilize a uniquely designed multi-speed motor. While the cooling is taking place, the chaff tray becomes integral as the fan cools the beans and separates the chaff from the beans by pushing them into the tray for easy disposal.

Part II: Coffee Roasting

About Roasting:

For those new to roasting coffee, it is in many ways easier to do than barbecuing a steak and slightly more difficult than boiling water, all because of the senses. First, you can *see* the transition of the beans going from green to brown. You can also utilize another sense, that of sound. In the case of coffee beans, Mother Nature provides a natural “pop up thermometer” *per se* via sounds of cracking at defined points in the roasting process. Lastly smell. Distinct changes in fragrances occur, as the beans progress through the various stages of roasting.

Coffee beans go through changes as the internal temperature rises. As the beans hit a light tan stage, the bean has expanded and the aroma changes from that of grassiness to that of sugars caramelizing. This is nature’s way of preparing you for what is about to occur: the first crack.

The terms first crack and second crack are terms frequently used in coffee roasting and defined as:

First Crack*: The first distinct – albeit sporadic -- sounds indicate that roasting is beginning to occur. Beans start to emit their water content via steam as sugars within the bean start to caramelize. The bean structure itself starts to change with bean expansion.

Second Crack*: The second distinct set of sounds will also be initially sporadic, but usually more pronounced than the sounds of the first crack. Beans have expanded to their largest point and in some cases tiny bits of bean will explode away from the bean. If allowed to continue into second crack the sporadic nature of cracks will then sound similar to rice cereal after milk has been added. Smoke increases dramatically at this point.

The progression from 1st crack to 2nd crack.

The first series of cracks will last somewhere between 1-1.5 minutes depending upon on bean type and quantity of beans being roasted. Think of this series of cracks as your alarm bell. Your coffee is now tan and, depending upon ones own tastes, or bean type, can be stopped from this point on.

The beans then go silent. During this period, the coffee is taking on more of its distinct flavors, darker colors, the roasting cycle can be stopped and cooling begun, depending upon one’s own tastes and bean type.

If you’ve chosen to try a darker roast you’ll then start to hear cracking sounds start up again. This is the second crack. Again, the sounds will initially be irregular. Now is when most of the greatest nuances and flavor characteristics emerge.

At this time manual cooling can be started if the timer hasn’t run down to default into cooling.

*Most excellent single origin coffees and some blends invariably show their greatest character when sent into the cooling stage at the start of or at a point just prior to the second crack.

Should you decide to allow the roast to continue into second crack, the snapping sound will become very rapid and similar to that of rice cereal. Care must be taken at this point to be ready to press the cool button, as smoke levels will rise rapidly. **If heavy smoke is seen, begin cooling immediately.**

If you do choose a darker roast where oils are present, simply let the beans continue into the second crack. We strongly recommend you reduce the amount of coffee you are roasting to ½ pound or less for darker roasts. **Never roast past 10 seconds into 2nd crack. If heavy smoke is seen, begin cooling immediately.**

Part III: Controls, Functions and Components

In the box you should receive:

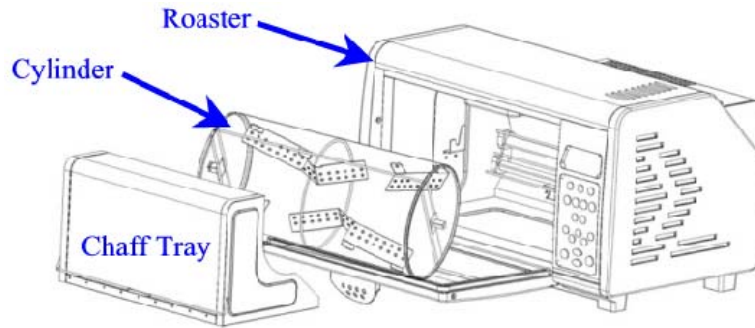

and brush (not pictured)

Basic Functions and System Components:

Control Panel:

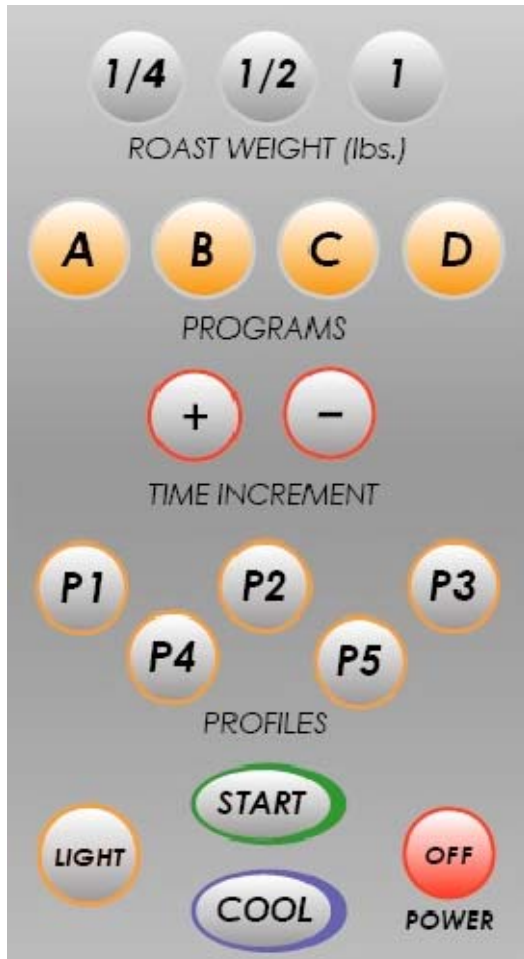

Roast Weights: Weight of green coffee beans to be roasted and system on switch. The weight buttons also act as default settings, allowing the user to “reset” the program at anytime before pressing start.

Programs/Times: System roast times directly associated with the weight chosen. See Tips and Maintenance for more complete information related to these examples.

Time Increments: Add or subtract time to/from the roast programs prior to start or at any point during roast cycle. Pressing “+” adds 15 seconds, “-” subtracts 10 seconds.

Profiles: Denote how heat is applied to the beans. P1 is the highest heat application, thus fastest roast time. P5 is the lowest overall heat application, thus slowest roast time. See Diagram of Profiles for details on heat applications along with Tips Section for more details.

Start: Starts the roasting cycle.

Cool: Allows the user to stop a roast at any time and begin cooling the beans,

Light: Light switch for viewing beans

Off: Ceases all system functions. DO NOT press OFF during the roast cycle **except** in an emergency situation (such as fire). Pressing OFF before the roast cycle is complete could lead to excessive smoke and possibly create a fire hazard.

Part III: Controls, Functions and Components Continued

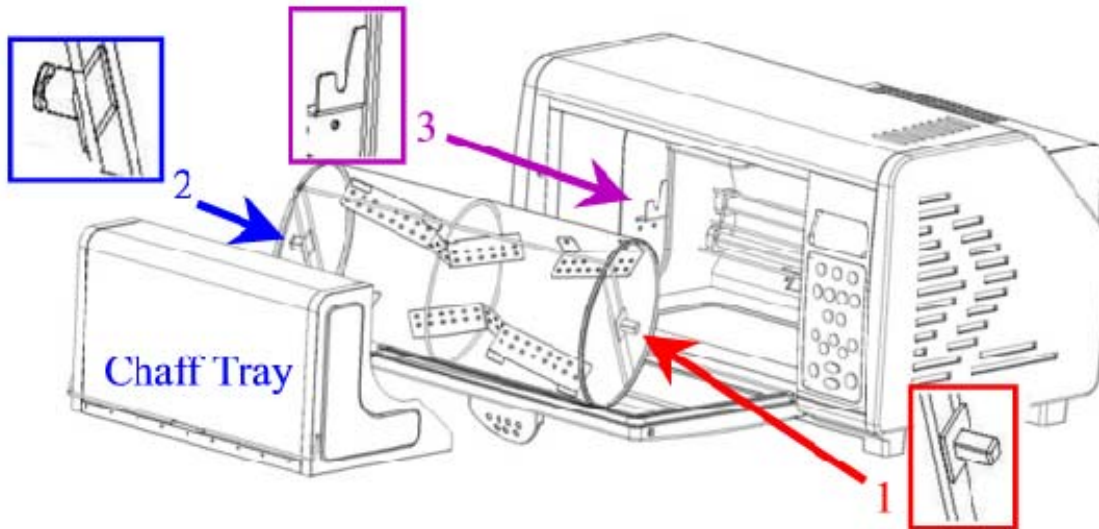

Cylinder: The cylinder (see above) has been designed for ease of use. One end has a square peg (red arrow- #1), which can only fit into the motor drive (inside right-not shown), with the left end having a grooved round peg (blue arrow- #2) whose groove drops into the holder's (purple arrow- #3) slot. The standard cylinder that ships with the roaster is not designed for use with small bean types such as Ethiopian, Yemeni or blends containing either. A separate cylinder w/ smaller grid is available through your retailer for use with those bean types or blends

Chaff Tray: Collects chaff that falls from the cylinder and pushed into the tray by the cooling fan. Once the beans have finished a complete cycle of both roasting and cooling, open the door. The majority of the chaff should be in the tray. The tray can then be used as a "dust pan". Remove the tray; remove the cylinder, then using the brush sweep the remaining chaff into a pile. Place the tray at the lip of the roasting chamber and using the brush, sweep the remaining chaff into the tray.

Roast Cycle: The system has been designed to read the data input (weight, time, etc.) and adjust system functions accordingly. The initial start times are the basis for the Profiles but times can be adjusted up (+ equals 15 seconds added) or down (- equals 10 seconds subtracted) at any time prior to start or during the roast. When the roast time has reached 59 seconds remaining, the digital display will blink on and off alerting you to time remaining until roast completion. If you desire to add time, you can do so up until a display time of 00:01. If you allow the system to go to 00:00, it will automatically go into its pre-programmed cooling cycle. WHEN THE SYSTEM GOES INTO COOLING DO NOT RESTART THE ROAST CYCLE. DOING SO WILL CREATE TREMENDOUS AMOUNTS OF SMOKE AND POSSIBLY CREATE OTHER HAZARDS.

Cooling Cycle: The system has two cooling cycle programs. One is an automatic cooling cycle that starts once the roasting timer goes to 00:00. When cooling begins, the display will show the countdown time for cooling. There is also a manual cooling cycle option available to the user. Should you decide at any time to end a roast, simply press the cool button and roasting will cease and cooling will begin. As with automatic cooling, the system timer will reset and show a new countdown for the cooling cycle.

Each system's function has been designed for a reason. It is imperative you allow the system to perform as designed for optimal performance and longevity. This is especially true of the cooling cycle. Failure to comply with these recommendations or those listed in the Important Safeguards could result in a potential safety hazard.

If you do not understand a function or parts of the system, email us at tech@behmor.com and we will do our best to answer any/all questions you might have. Please include a phone number so we can, if necessary call to better communicate an answer to you.

Part IV: System Preparation, Start-up and Programming

System Check:

To insure all functions are working properly press each button within each group in the following order: Press all Weight buttons starting with ¼, ½, to 1 noting time in the display changes. Next, Profiles starting with P1 through P5, noting changes on the display. Next, Programs A through D, again noting display changes. Next press, each (+ then -) Increments, Light, Cool, then lastly OFF. Start will be tested in the next step.

Preparing the Behmor 1600 for Use:

Before first use, clean the interior of the roasting chamber with a moist cloth. At the same time check the cylinder, oven chamber and all areas of the chaff tray for stray packing material. If found remove. Then, insert the cylinder and chaff tray in their proper locations and close the door.

Press  

This procedure, also referred to as a dry burn, is necessary to help eliminate any residue left in the roaster during the manufacturing process while also serving to “season” the roaster and door gasket. During the first few roasts you may see some very faint smoke from the exhaust or gasket area but this should cease as the system self cleans, seasons and fine-tunes itself. This same procedure is used for periodic system self-cleaning as described later in the Tips and Maintenance section.

Getting Started:

Take the roasting cylinder and insert the desired amount* of green coffee beans, close the cylinder, making sure the cylinder clasp is securely in place.

Next, with cylinder in hand, carefully place the cylinder into the roasting chamber as shown previously, inserting the right end (square peg) into the motor drive while laying the left end (round peg w/groove) onto the holder. You may find the square peg might require slight rotation of the cylinder for it to slide fully into place. You’ll know it is in place when the left (round) side’s groove drops into the holder’s cut away. **Always double-check to insure the cylinder is properly in place.**

Install the chaff tray by sliding the tray into the roasting chamber and pushing the tray toward the back until it will go no further. Improper placement of the tray can lead to chaff being blown outside the tray.

Close the roaster door ensuring the door is closed tightly.

* Whether new to, or experienced with roasting coffee we strongly suggest you start off by roasting several ¼ pound batches to begin developing an understanding of the subtle nuances of roasting coffee with the Behmor, the snaps described earlier, and the aromas associated with these snaps. We also suggest to always forward think your roast by 10 seconds. Following this suggestion will lead to a greater enjoyment later.



Reminders

- 1) Never leave the roaster unattended when roasting coffee.**
- 2) Always roast in a well-ventilated area.
- 3) Never roast past 10 seconds into 2nd crack.
- 4) You can add or subtract time at any point prior starting a roast or during a roast adding up to the maximum times allowed.
- 5) You can end a roast at any time by pressing the cool button.
- 6) Time between start of 1st crack and 2nd is stated in Tips and Maintenance item # 2. These are very good to know and a great guideline when roasting especially when using Profile 2 (P2).
- 7) If at any time prior to start you make a mistake. Hit your appropriate weight and everything resets to the start/default point.
- 8) Allow 1 hour between roasts

Using the following chart you can now begin roasting. For Quick Starts use Default P1. For slower roasts or varying roast profiles simply use the charts as shown.

Part IV: System Preparation, Start-up and Programming continued

Quick Start Default P1- Hard Bean

Weight - Profile	Press in following order	Start Time / Max Time**
¼ Pound roast - P1 (default)		8:30 / 10:00
½ Pound roast - P1 (default) * Also used for system self-clean/dry burn		12:00 / 13:30
1 Pound roast - P1 (default)		18:00 / 20:30

Profile P2 - Hard Bean

¼ Pound roast – P2		9:30 / 10:30
½ Pound roast – P2		13:00 / 14:30
1 Pound roast – P2		20:00 / 22:30

Profile P3 – Soft bean/low grown: example Brazilian

¼ Pound roast – P3		10:00 / 11:00
½ Pound roast – P3		14:00 / 15:30
1 Pound roast – P3		21:30 / 23:30

Profile P4 – Soft bean or espresso blends

¼ Pound roast – P4		10:20 / 11:30
½ Pound roast – P4		14:40 / 16:30
1 Pound roast – P4		22:40 / 24:30

All start times are based on in home tests to take beans up to 2nd crack based on 116v environments. Roasting times will vary according to actual in home voltage. P4 and P5 times shown have been adjusted to match in home times to 2nd crack. See further data in Tips and Maintenance on voltage/ time issues.

* System self clean/dry burn as explained in Tips and Maintenance Section

**Maximum Times denote the maximum allowed roast time per pre-set profile and weight. This feature is meant to limit possible fire hazard. See further data in Tips and Maintenance.

Part IV: System Preparation, Start-up and Programming continued

Profile P5- Hawaiian, Jamaican etc./ Island Coffees- City/City+

Weight - Profile	Press in following order	Start Time / Max Time*
¼ Pound roast – P5		10:45 / 12:30
½ Pound roast – P5		15:30 / 17:30
1 Pound roast – P5		23:30 / 25:30

All start times are based on in home tests to take beans up to 2nd crack based on 116v environments. Roasting times will vary according to actual in home voltage. P4 and P5 times shown have been adjusted to match in home times to 2nd crack. See further data in Tips and Maintenance on voltage/ time issues.

*Maximum Times denote the maximum allowed roast time per pre-set profile and weight. This feature is meant to limit possible fire hazard. See further data in Tips and Maintenance.

Part V: Tips, Maintenance, FAQs and Troubleshooting:

Tips and Maintenance

- Always [forward think your roast](#) by 10-15 seconds. This is the amount of time that is required to start reversing the trend from roasting to cooling.
- [After five roasts cycles, you must always perform a system self clean.](#) To do so, insert the cylinder (empty), chaff tray, close the front door. Press ½ then Start and let the system complete an entire roast and cool cycle. Failure to perform this maintenance procedure will in time adversely affect your roaster's functionality and longevity.
- The following time spans are good set of [guidelines to better anticipate a roast hitting 2nd crack.](#) The times shown are approximately what it takes from start of the first crack/snap of 1st crack to the start of 2nd crack. This guideline is especially important to know when using Profile 2/ P2. We have found over the course of many tests using P2 it will give you only a few 1st cracks then go silent, moving gently into 2nd crack in the times shown below. We suggest adjusting times as close to the following once you hear the first cracking sound of 1st crack. This should allow you to more accurately control your roast.
 - ¼ lb - 1:40 minutes
 - ½ lb - 2:20 minutes
 - 1 lb- 3:20 minutes
- Roasting times may vary due to voltage, but a good understanding of the A, B, C, D (Program /Times) to Profiles P1, P2, etc., is as follows:
 - A to P1
 - B to P2
 - C to P3
 - D to P4 (subtract 30 seconds using)
 - D to P5 (add 30 seconds using)
- Associated [initial start times](#) of A, B, C, D to weights ¼ , ½ , 1 (see Chart on next to last page)

	¼	½	1
A	8:30	12:00	18:00
B	9:30	13:00	20:00
C	10:00	14:00	21:30
D	10:30	15:00	23:00

Part V: Tips, Maintenance, FAQs and Troubleshooting continued:

- 6) In order to prevent possible issues with over roasting, we have built in [maximum roast times associated with each profile](#). If you should happen to be roasting at P1, the system is designed to prevent you from allotting more than 20:30 minutes roast time. This is a safety feature. The same feature is true for the other profiles but with longer times. See Chart below:

	1/4	1/2	1
P1	10	13:30	20:30
P2	10:30	14:30	22:30
P3	11	15:30	23:30
P4	11:30	16:30	24:30
P5	12:30	17:30	25:30

* When using P1 or P2, in certain instances, Program times C and/or D, may appear not to function. This was designed to occur. In those instances C and/or D's pre-programmed start times exceed the maximum allowed roast time for that profile.

- 7) For [quicker cool down](#) an option does exist, should the user decide take the following measure. After the beans have ceased snapping (approximately 1:30), while keeping the system on cool, simply open the front door. Doing this will facilitate a greater airflow over the beans. The one drawback is small amount of chaff will find it's way past the chaff tray.

NEVER STOP THE SYSTEM IMMEDIATELY AFTER COMPLETING A ROAST TO REMOVE THE CYLINDER AND COOL THE BEANS. DOING A SYSTEM STOP BEFORE REASONABLE COOLING COULD DAMAGE THE SYSTEM'S INTERNAL ELECTRONIC COMPONENTS.

- 8) [Adjusting profiles by time additions and subtractions](#) at proper times can be used to slightly alter the pre-programmed profiles. You can shorten or lengthen the middle leg of a profile or end leg of a profile in terms of percentage to total time. The adjustments can be made by prior to or just after starting the roast cycle.

Example: P5 is 33% of each power application throughout the entire roast. Thus if you were to set the timer at 6:00 minutes each leg of the profile would last approximately 2:00 each.

However if you were to set the timer for 6:00 minutes to begin with, then upon starting a roast add 2:00 minutes you will have immediately reduced the middle leg's total percent of total roast to 25% versus the original 33%.

Conversely let us say you want to lengthen the middle leg and shorten the end leg of the roast. Before starting press the timer to read 10:00. The system then reads it is to run approximately 3:20 per leg. Once starting however reduce the time to 8 and you will have the first legs of the roast at 3:20 each but the final leg at 1:20.

If you wish to shorten the roasts middle leg percentage to total and lengthen the end leg, reduce times to start, then once started add time back.

If you wish to lengthen the roasts middle leg percentage to total and reduce the end leg, add time to start, then once started reduce the time back.

The possible variations number in the hundreds once you understand the roaster and the beans you are roasting.

Part V: Tips, Maintenance, FAQs and Troubleshooting continued

FAQs and Troubleshooting

<p>My system stopped and an error message reads:</p> <ol style="list-style-type: none"> 1) Err1 2) Err2 & Err3 3) Err4 4) Err5 5) Err6 	<ol style="list-style-type: none"> 1) Thermostat is damaged 2) Coffee beans have burned or the oven chamber has experienced an unacceptable rise in heat 3) Draw fan is damaged 4) DC fan is damaged 5) DC motor (cylinder) is blocked or damaged. 	<ol style="list-style-type: none"> 1) Call or email tech support 2) Let system cool for a minimum of 3 hours, then retry. Should problem persist, call or email tech support for immediate service 3) Call or email tech support 4) Call or email tech support 5) Call or email tech support <p>tech@behmor.com or 775-833-3363</p>
<p>In cooling I noticed a little smoke leakage</p>	<p>We have worked to seal the door area and other tiny cracks, but to totally seal the system is impossible. On rare occasions, you might see a wisp of smoke</p>	<p>We advise gently cleaning the door seal on a regular basis with a damp cloth to ensure no chaff or other particulate matter prevents a proper seal.</p>
<p>When roasting, I noticed a little smoke from the exhaust.</p>	<ol style="list-style-type: none"> 1) Occasionally, whether due to the quality of the beans, the darkness of the roast or even the quantity/darkness of the roast, small amounts of smoke may be seen. 2) During the first couple of roasts there may be a little smoke as the system “seasons” itself. 3) Home wiring could be old and doesn’t supply a sufficient amount of voltage to run the system properly. 	<ol style="list-style-type: none"> 1) reduce the quantity of that type of bean when it is noticed it tends to smoke. 2) On subsequent roasts the smoke should go away. 3) Try different power outlet whose line may carry a greater amount of voltage
<p>Sometimes I notice, even when I’ve added time I can’t complete a roast.</p>	<p>In some instances and in some homes there will and can be voltage issues that are outside our control.</p>	<ol style="list-style-type: none"> 1) Try using a different outlet. In some cases an outlet only a matter of a few feet away can and will have better voltage input and sustainability. 2) Try roasting at a different time of day. As is true throughout the country during summer the afternoons are when the largest power consumption occurs
<p>I tried the above and I still have the same problem.</p>	<p>In older homes where the wiring goes back to the copper clad aluminum days or further back where you have consistently low voltage.</p>	<ol style="list-style-type: none"> 1) If wanting to roast the maximum we suggest reducing the quantity from 16 ounces to 13-14 ounces yet still using the 1 pound programs. 2) If you want to roast using ½ pound setting with either profiles (P2-5) we suggest using 6 ounces of green coffee.
<p>While the chamber was still warm I opened the front door and noticed the gasket is wavy in appearance and not glued down</p>	<p>The gasket is attached using tiny nipples and not glued so the expansion and contraction caused by heat up and cool down has no ill effects on the materials</p>	<p><u>Do nothing</u> this has been designed to be as it is.</p>
<p>When the cylinder is turning I hear squeaking.</p>	<p>Like any metal to metal rubbing, in time noises can be emitted.</p>	<p>Take a Q Tip or similar, place a drop of <u>food oil</u> (olive, veg etc.) on it. Now rub the Q Tip in the grooved area (round peg) of the cylinder</p>

Part V: Tips, Maintenance, FAQs and Troubleshooting continued

Only use the Behmor 1600 a well-ventilated environment and maintain at least 18”(eighteen inches) of clearance on all sides, this includes 18” clearance from the top and exhaust the vent.

In Case of Fire: Never open the chamber door.

The Behmor 1600 should automatically react to fire and shut down. Once the system has performed a shutdown, unplug the roaster and, if possible, move it outdoors for proper venting. Causes of such a fire would likely be traced back to using a high chaff coffee or allowing a roast to go past 10 seconds into 2nd crack. As instructed earlier, we strongly advise against the use of high chaff producing coffees or roasting past 10 seconds into 2nd crack .

If the system should not shut down because of fire, as instructed earlier in the Important Safeguards, stop the roast and unplug the roaster. Then move it outdoors when safe to do so.

AGAIN NEVER open the chamber door if a fire occurs.

For any other problems, please email tech support- tech@behmor.com. Please tell us what you were doing, where you were in the roasting process-as best you can, and identify the issue as much as possible. Please also include phone number or other contact information so customer service can respond.

Higher resolution Profile Charts are available at our website

Please remember to register your roaster and check for manual updates monthly.

Online registration: www.behmor.com

Manual updates: www.behmor.com/manual.com

Be sure to include you email address to receive any updates regarding manual changes, special promotions or other items.

REMEMBER

Never leave the roaster unattended when in use !!!!

Weight (1/4, 1/2 , 1) to Program (A,B,C,D) Roast Times*

1/4 LB ROASTS

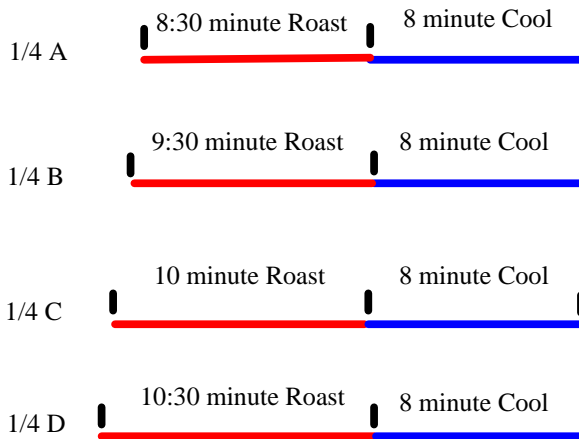

1/2 LB ROASTS

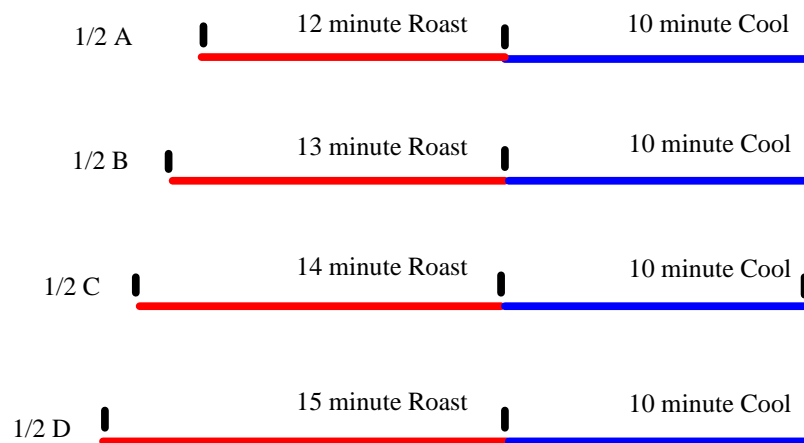

1 LB ROASTS

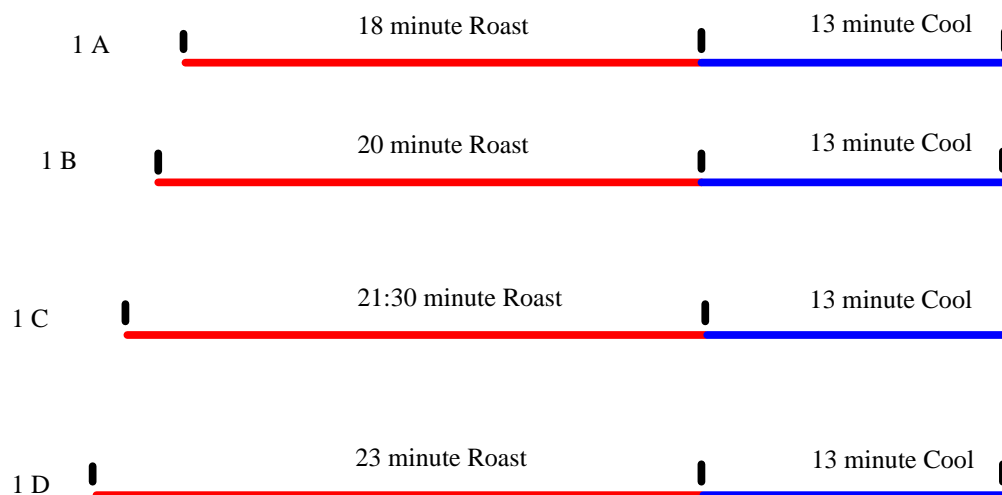

*all roast times shown are pre-programmed defaults prior to any user's optional adjustments

Roast Profiles/Heat Applications

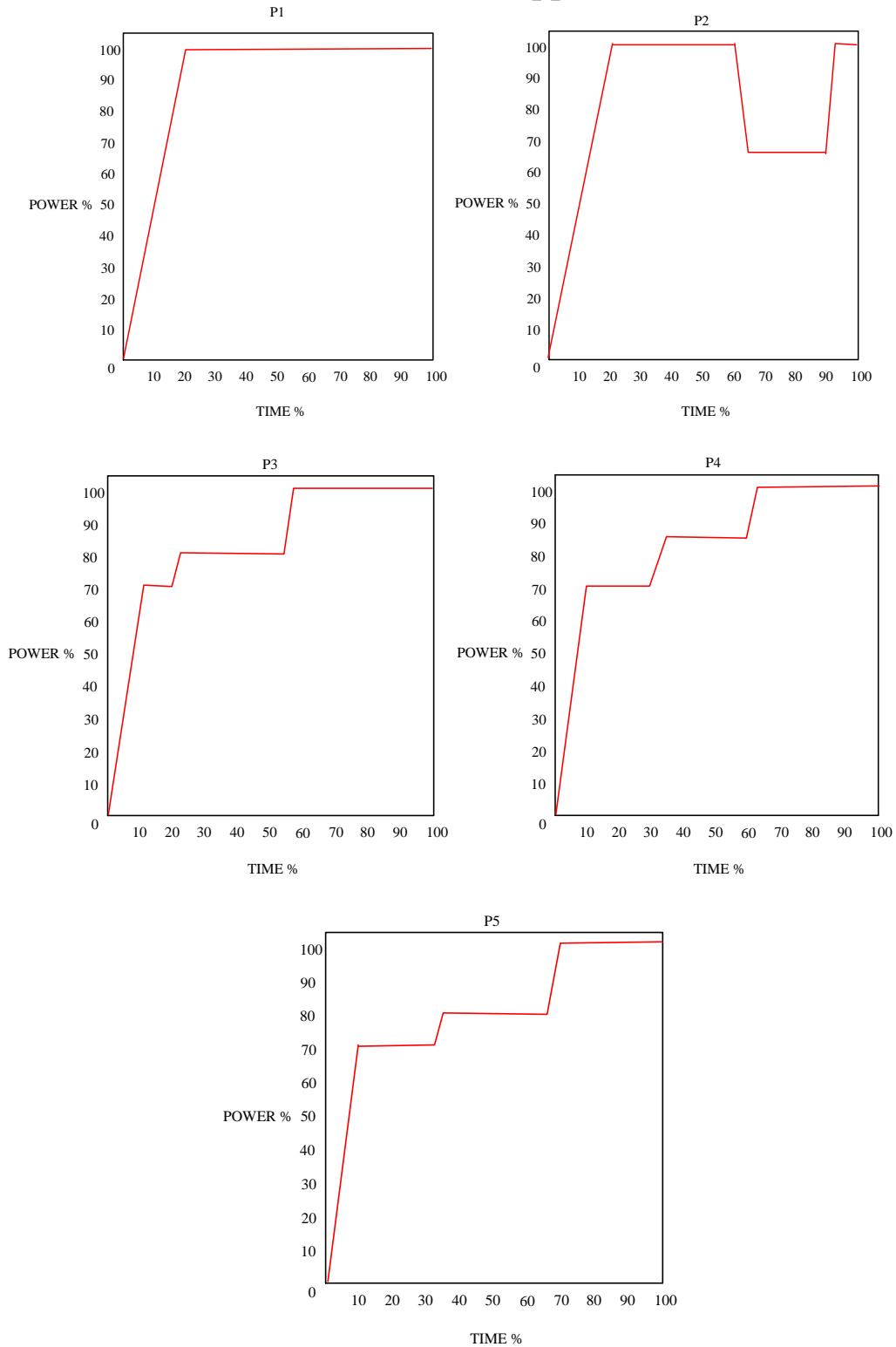

Legend:

100%= 250c or 482f

90%= 230c or 446f

80%= 210c or 410f

70%= 190c or 374f

**** above profile data is for illustrative purposes only**

