

# **Behmor Inc. BT1000NV**

## **Low Profile Chaff Tray**

### **Installation and Proper Placement Instruction Guide**

The introduction of our redesigned Low Profile Chaff Tray represents our commitment to improve the roasting experience and results for our users. The Low Profile Chaff Tray significantly improves bean visibility, enhances airflow for improved cooling, as well as collects chaff better than its predecessor.

**To Use:** Before inserting chaff tray, ensure the flap (below left- 4 a) is in a “roast” position. It should be slightly downward so as the cylinder rotates, it pushes the flap into a non-intrusive position, yet still captures floating chaff. Next depress the spring-loaded handle downward (see below). This allows the vanes to drop flat for cylinder clearance. Slide the chaff tray under the cylinder, releasing the handle after the tray is in place.

**Trays may ship w/ Protective plastic-Remove by peeling off**

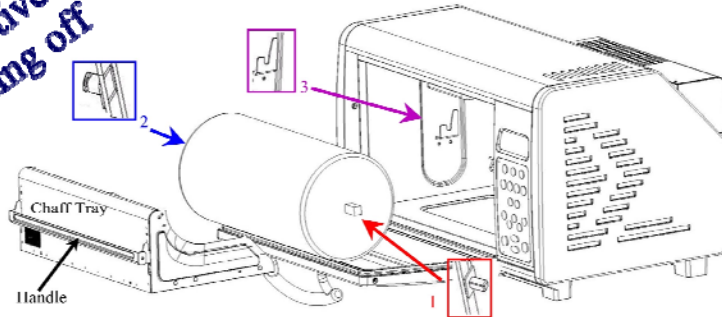

**To Clean:** To remove the chaff tray, depress the handle to flatten the vanes, and slide the tray out of the chamber.

Swing the flap up ( shown in 4 b) from its “roast” position (4a) to allow the tray contents to be dumped. Remember to move the flap back into a downward “roast” position (4a) in preparation for your next roast.

\* **Preheat:** We’ve found through testing, a more robust roast can be achieved by doing a 1 minute preheat\*\* of the system. Press any weight, start and allow to run 1 minute. Press stop, insert cylinder, tray and start your roast. Remember use caution while working around hot surfaces.

**\*\*Preheat for 1 minute only**, any longer could activate a safety feature, which prevents a restart!

### **Proper Chaff Tray Placement**

Ensure the chaff tray does not impede the rotation of the cylinder. Proper placement is imperative. Please take a moment to do the following:

- 1) Open the roaster door. Note the grill that protects the roasting (quartz) elements extends across the back except for small gaps ( arrows #5 below) on the left and right sides.
- 2) Take the chaff tray and slide it in.
- 3) Be sure the front of the chaff tray’s sidewalls ( #6 arrows below) slide all the way into the gaps ( #5 arrows).

Make a mental note of the tray position (both front and back) for future reference.

Flap in downward "roast" position

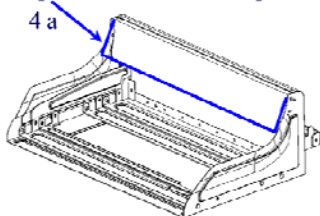

Flap up "cleaning" position

